

SAFE-AID TS 7000 TELESCOPIC CRANE OPERATORS MANUAL

! WARNING !

THE PURPOSE OF THIS MANUAL IS TO PROVIDE THE CUSTOMER WITH THE OPERATING PROCEDURES ESSENTIAL FOR THE PROMOTION OF PROPER MACHINE OPERATION FOR ITS INTENDED USE. THE IMPORTANCE OF PROPER USAGE CANNOT BE OVERSTRESSED. ALL INFORMATION IN THIS MANUAL SHOULD BE READ AND UNDERSTOOD BEFORE ANY ATTEMPT IS MADE TO OPERATE THE MACHINE.

SINCE THE MANUFACTURER HAS NO DIRECT CONTROL OVER MACHINE APPLICATION AND OPERATION, CONFORMANCE WITH GOOD SAFETY PRACTICE IN THIS AREA IS THE RESPONSIBILITY OF THE USER AND HIS OPERATING PERSONNEL.

ALL PROCEDURES ARE BASED ON THE USE OF THE SYSTEM UNDER PROPER OPERATING CONDITIONS, WITH NO DEVIATIONS FROM THE ORIGINAL DESIGN. ALTERATION AND OR MODIFICATION OF THE EQUIPMENT IS STRICTLY FORBIDDEN WITHOUT PRIOR WRITTEN APPROVAL FROM ELEC-MECH (PTY) LTD.

THE SAFE-AID TS7000 (RATED CAPACITY INDICATOR (RCI)/LOAD MOMENT INDICATOR (LMI)) IS ONLY TO BE REGARDED AS AN AID TO THE OPERATOR. WHEN THE PARAMETERS ARE SET CORRECTLY, THE INDICATOR WILL WARN THE CRANE OPERATOR OF AN APPROACHING OVERLOAD CONDITION OR A CONDITION THAT COULD CAUSE DAMAGE TO EQUIPMENT, PROPERTY, AND/OR INJURY TO THE OPERATOR OR THE SITE WORKERS IN THE VICINITY OF THE CRANE AND ITS LOAD.

THIS SYSTEM UNDER NO CIRCUMSTANCES MUST BE USED AS A SUBSTITUTE FOR THE GOOD JUDGEMENT OF A CRANE OPERATOR WHEN CARRYING OUT APPROVED CRANE-OPERATING PROCEDURES, THEREFORE THE RESPONSIBILITY FOR THE SAFE OPERATION OF THE CRANE LIES WITH THE CRANE OPERATOR. THE SYSTEM WILL NOT NECESSARILY PREVENT DAMAGE DUE TO OVERLOADING AND RELATED CAUSES, IF NOT SET PROPERLY.

BEFORE OPERATING A CRANE EQUIPPED WITH A SAFE-AID TS7000 RCI THE OPERATOR MUST READ THE INFORMATION IN THIS MANUAL CAREFULLY. CORRECT FUNCTIONING OF THE SYSTEM DEPENDS UPON ROUTINE DAILY INSPECTION AND ANY SUSPECTED FAULTS OR APPARENT DAMAGE SHOULD BE IMMEDIATELY REPORTED TO THE RESPONSIBLE PERSON BEFORE USING THE CRANE.

Contents

SYSTEM USE.....	3
SYSTEM STARTUP – FIGURE 2.....	4
5TH OUTRIGGER (FRONT JACK) SELECTION – FIGURE 3.....	5
MAIN OR AUXILARY WINCH SELECTION – FIGURE 4.....	6
PROGRAM SELECTION – FIGURE 5.....	7
REEVING – FIGURE 6.....	8
DEDUCTIONS – FIGURE 7 & 8.....	9
OPERATING SCREEN – FIGURE 9.....	10
ERROR MESSAGES - FIGURE 10 AND TABLE 1.....	13
SAFE-AID TS7000 SYSTEM ERROR TABLE – TABLE #1.....	14
WORKING OPERATIONS.....	17
INDICATING STATUS LIGHTS AND DUMP OUTPUT (LEVER CUT-OFF) – TABLE # 2.....	18
TOUCH SCREEN CALIBRATION – FIGURES 11, 12 & 13.....	20
QUICK USE FLOW CHART.....	22
CONTACT DETAILS.....	23

SYSTEM USE

The TS7000 unit is designed with ease of operation in mind. The crane setup is selected and confirmed by the operator before the system goes into its normal operating/monitoring screen requiring no further input from the operator unless the crane configuration changes. Before this is done the crane will remain in safe mode, i.e. the dump circuit will be operational (if the crane has a dump system fitted). All inputs to the system are done by the operator via the touch screen including the buzzer override function and momentary bypass. The touch screen is sensitive to touch therefore it is **not** necessary to **push hard** on the screen (*if touch screen does not work or selects incorrectly see touch screen calibration*).

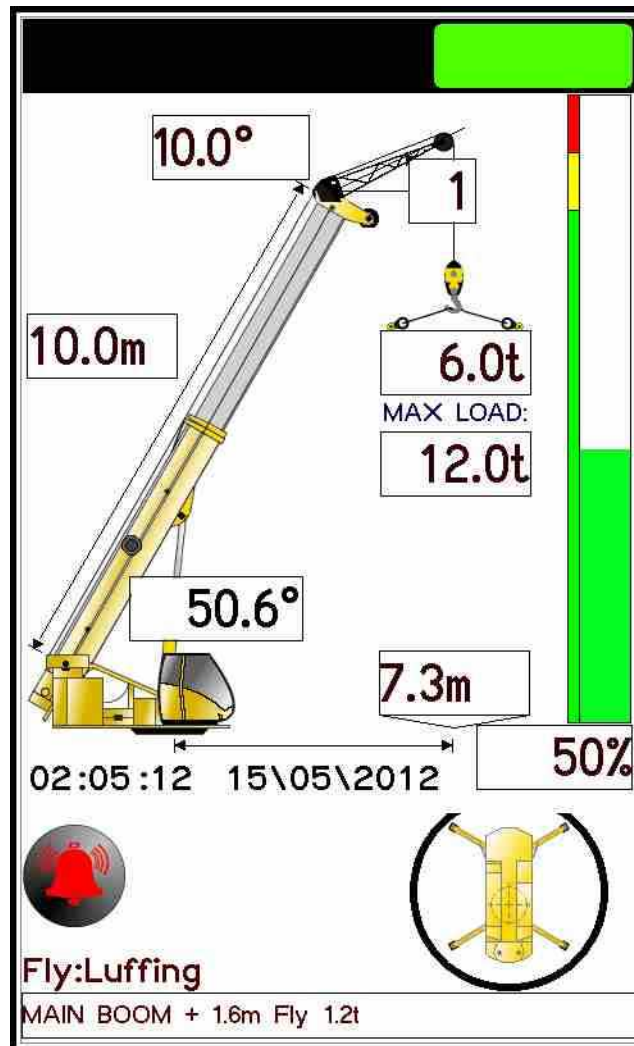

Figure 1

SYSTEM STARTUP – FIGURE 2

The TS7000 display (LMI) automatically starts up when the crane is powered on, the buzzer will sound intermittently and the green, amber and red VISUAL INDICATION BLOCKS will flash. The system initially runs through a set of internal diagnostics (Figure 2) to make sure all inputs and outputs are working correctly.

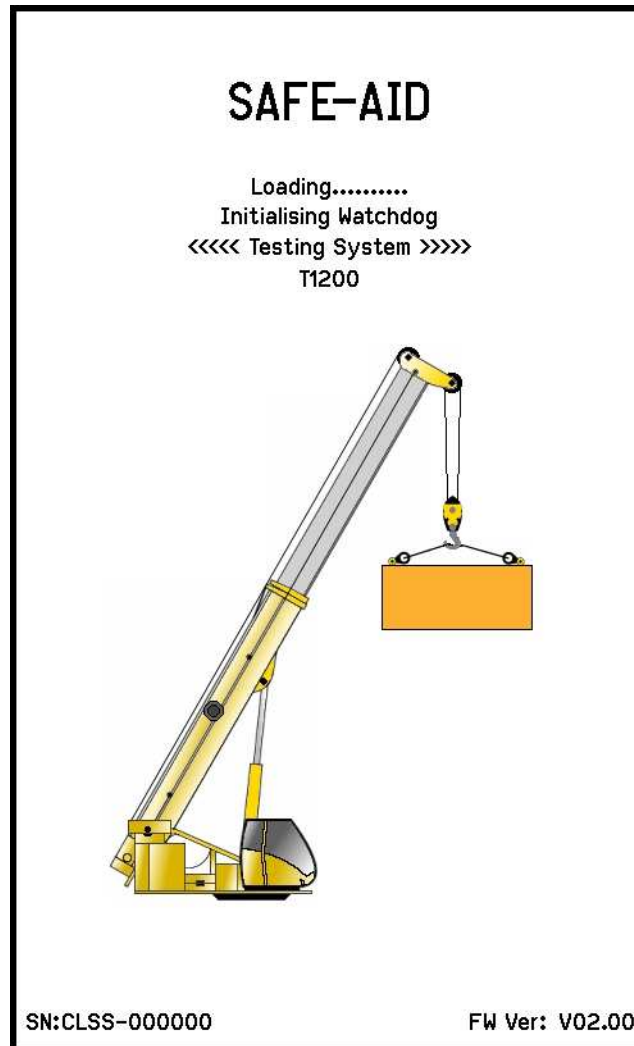

Figure 2

5TH OUTRIGGER (FRONT JACK) SELECTION - FIGURE 3

Note: If the crane does not have a 5th outrigger or the 5th outrigger is automatically monitored by a switch this step will be skipped.

Some truck mount cranes are fitted with a 5th outrigger (front jack) which can be extended (down) or retracted (up). This influences the rated capacities when working over the front of the crane either by decreasing the capacities or giving a slew error when the 5th outrigger is retracted (Figure 3). Simply key the option required - if the 5th outrigger is **down** then select **extended** if it is **up** select **retracted**.

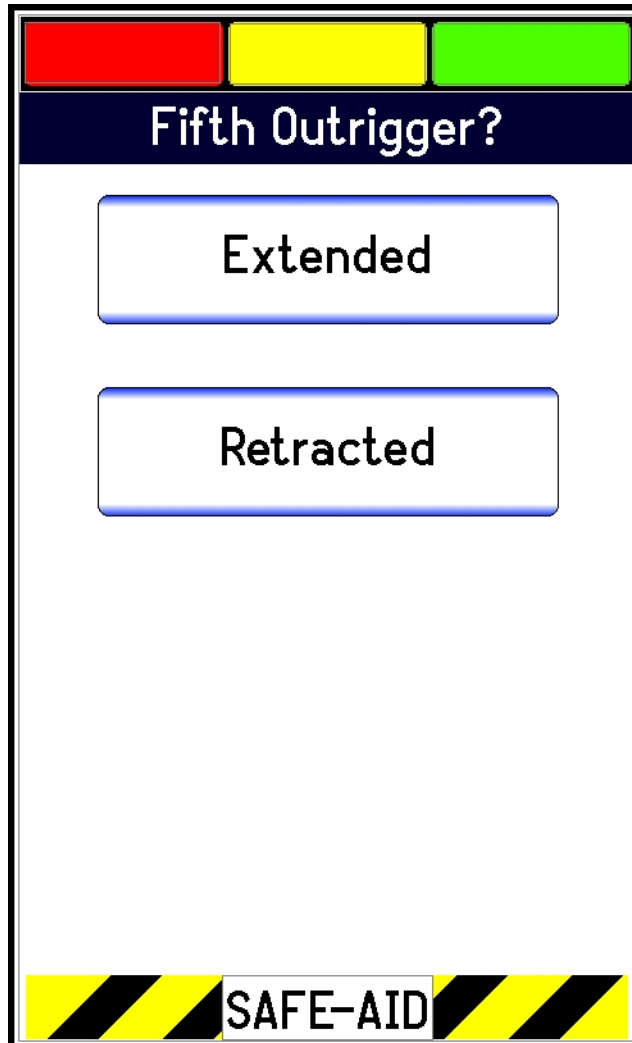

Figure 3

MAIN OR AUXILIARY WINCH SELECTION – FIGURE 4

Note: If the system has been programmed with only one winch option this step will be skipped.

The following option is to determine whether the main winch or the auxiliary winch (Figure 4) is being used for lifting. Simply key the option required - if the main winch is being used select **Main** and if auxiliary winch select **Aux**.

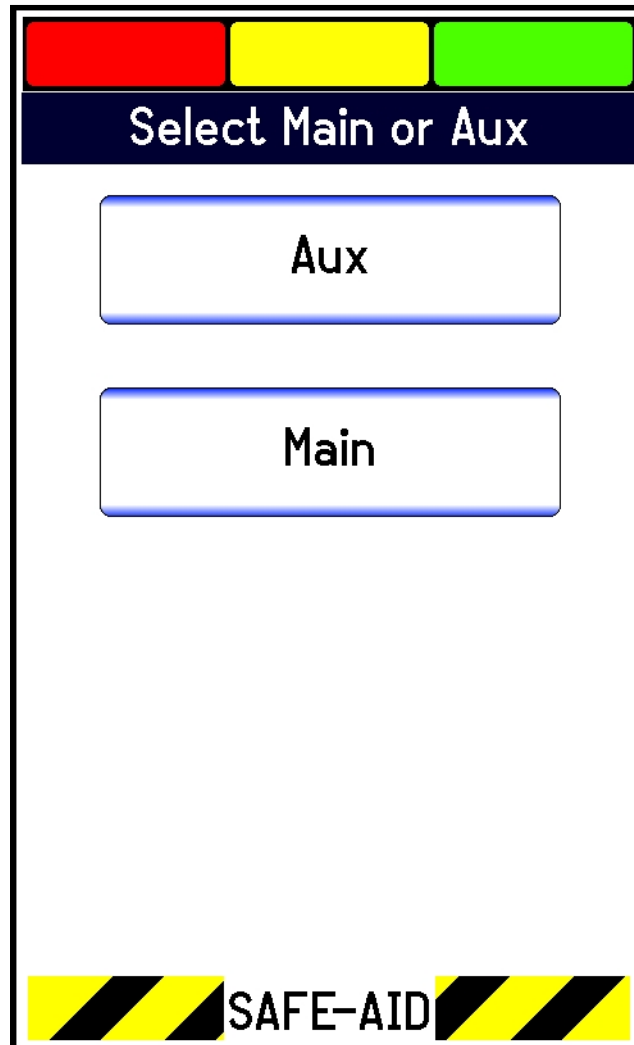

Figure 4

PROGRAM SELECTION - FIGURE 5

Note: If the system has been programmed with only one program this step will be skipped.

Each program can be selected by pushing on the program name that is required this will highlight the selected program. If needed scroll down through the programs either using the up and down arrow keys or by running a finger up and down on the scroll bar on the left of the screen. This will enable scrolling through all the programs. Once the applicable program has been highlighted, press the Select button to select the desired program. Some manufacturers have telescoping monitoring conditions that may require the boom to be full retracted before changing program, in this case a **Retract Boom** message will be displayed when trying to change the program with the boom extended.

The correct selection of the program is imperative as this determines the correct rated capacities and work areas. If selected incorrectly, a higher rated capacity than allowed could be selected for that crane configuration, this is very dangerous as it can cause the boom to bend / break or the crane to tip / fall over.

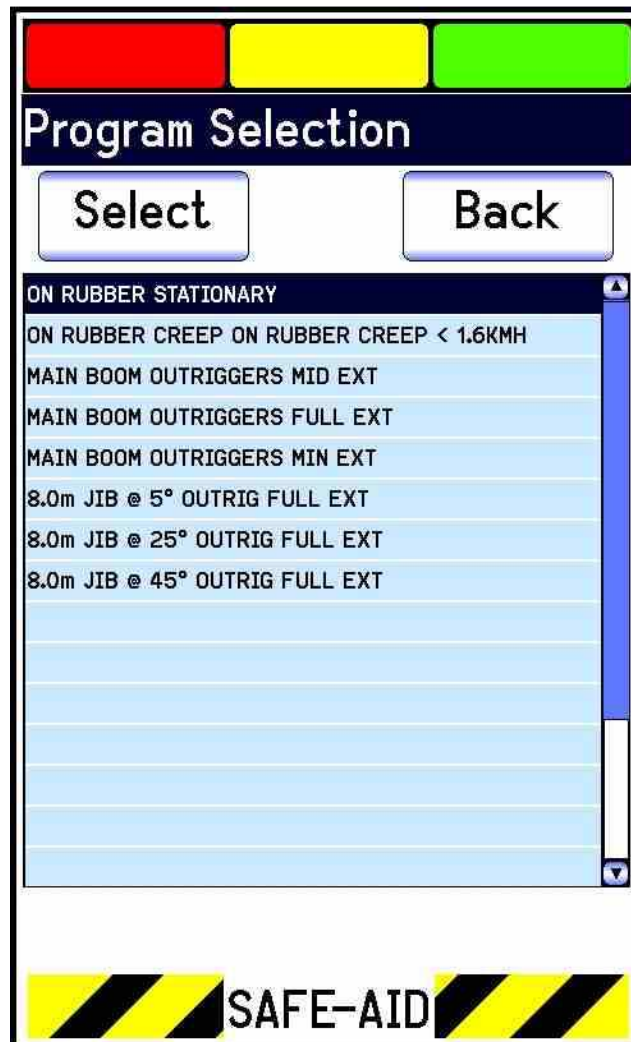

Figure 5

REEVING – FIGURE 6

Note: If the system has been programmed with fixed reeving or you have selected a fixed hook this step will be skipped.

After program selection, how many reeves (falls) the hook is reeved to (total parts of line between hook block and sheave wheels) must be selected. A numerical keypad will be displayed (Figure 6). Key in the number of reeves on the winch (i.e. Main or Aux), followed by the Enter key (e.g. if main winch was selected Reeving Main will be displayed). If the incorrect number is keyed in simply press the Clear button and start again. Once the Enter button is pressed the next selectable option or the operating screen will appear.

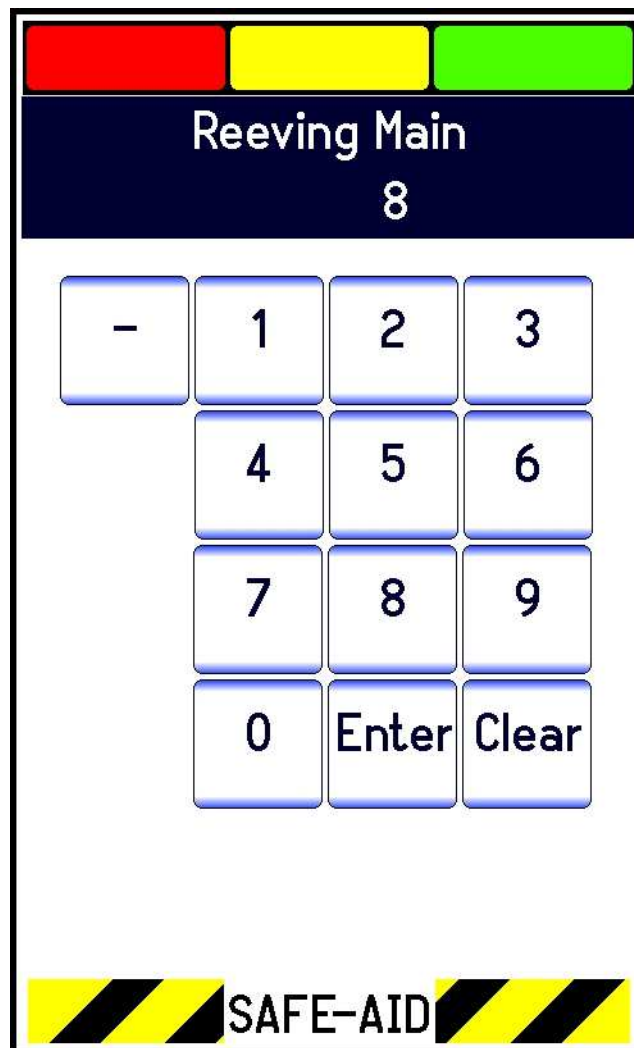
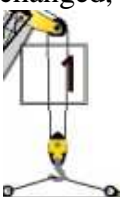

Figure 6

While working in the main running screen or if an error has been made and the reeving needs to be changed, press the block on the main running screen where the winch rope goes down to the lifted load and the system will respond by changing to the Reeving entry screen.



DEDUCTIONS – FIGURE 7 & 8

Note: If the system has NOT been programmed with deductions this step will be skipped.

On cranes where the main boom can be used with the fly jib erected or stowed, the crane manufacturer may give deductions that must be taken off the rated load when using that particular configuration. This is done automatically by the TS7000 by selecting the correct option when prompted (figure 7). If **Fly** is selected all the different fly options will be displayed (Figure 8), select the correct fly option (different mounting & storage options) and then press enter. If there is no fly stowed or erected **No Fly** will be selected, which means no deductions will be made from your rated capacities.

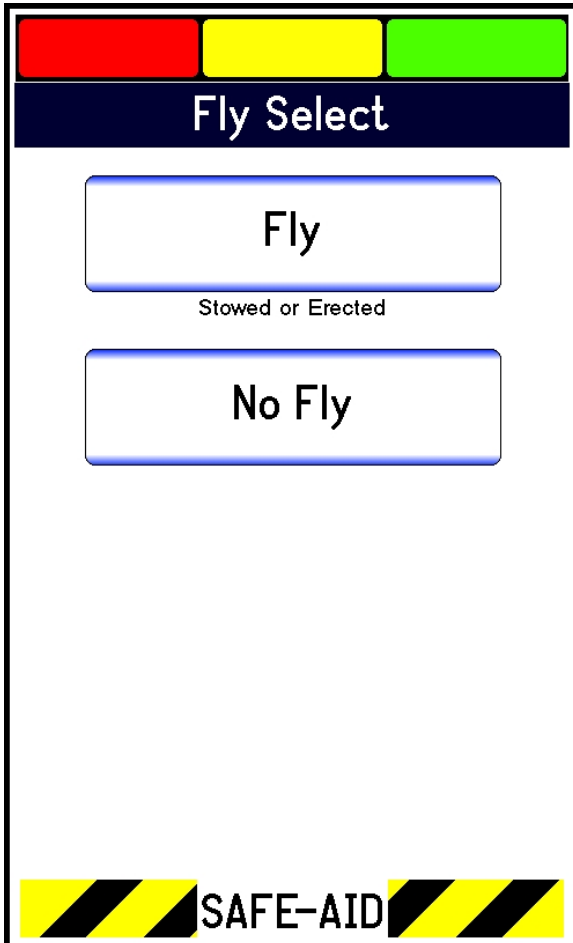

Figure 7

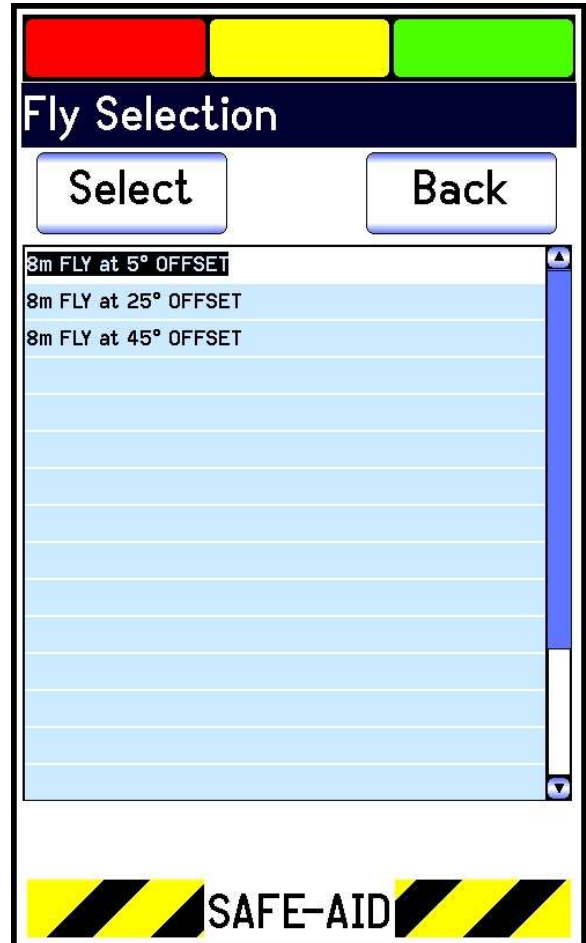

Figure 8

OPERATING SCREEN - FIGURE 9

All the crane and system information can be viewed from here including all the parameters selected from power up. Should a different program need to be selected, press the crane graphic on the screen, the system will go back to the beginning as on system start up. Repeat the steps above.

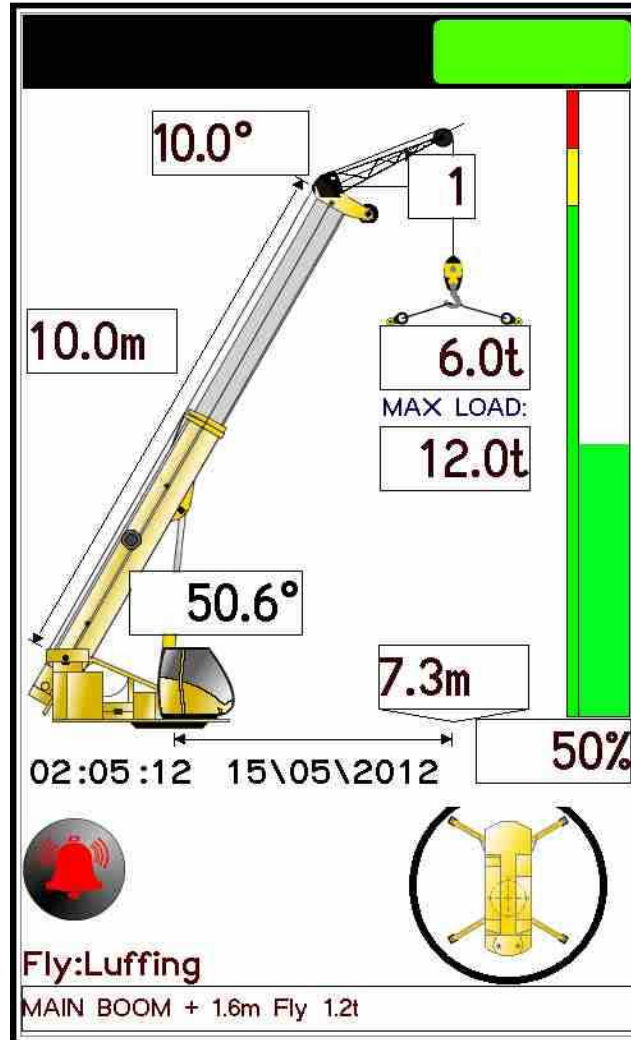

Figure 9

In operating mode, you can see all the current parameters of the crane.

Area Selection: This is not user selectable and shows the current area the crane is working in:



360 Degrees



Over Side & Rear

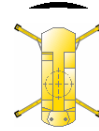

Direct over front

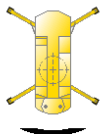

Direct Over Rear



Direct Over Front & Rear

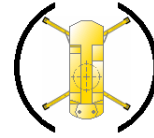

Over Side



Over Front and Side



Over Front Outrigger to Outrigger

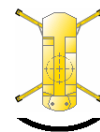

Over Rear Outrigger to Outrigger

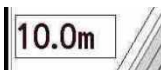

Length: This displays the current total main boom length.



Main Angle: This displays the main boom angle.

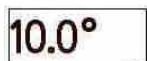

Fly Angle: If a fly is fitted, the fly angle will be shown in the fly angle box. A fixed angle will be shown for a fixed fly and for a monitored fixed fly or luffing fly the angle will change as the fly angle changes. The fixed fly angle is measured relative to the main boom i.e. 0° being straight with the main boom and increasing as the offset to the main boom increases while the luffing fly angle is measured relative to ground level i.e. 0° is the fly jib parallel to the level ground.

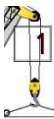

Reeving: This is the current reeving (number of falls) selected.

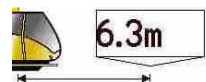

Radius: This is the current radius from centre line of rotation to the centre of the hook block (load) if the hook block (load) is hanging straight down.



Lifted Load: This is the load on the hook at the present time, if the green light and the load are flashing it is a tare load (the tare has been pressed).

MAX LOAD:

12.0t

Rated Capacity: This is the load allowed to be picked up with the selected configuration at that current radius as specified by the manufacturer.

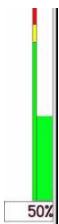

Utilisation: Percentage utilization is the percentage of rated load used by the current lifted load. This is also displayed graphically by the bar, going from green (0% - 89%), then amber (90% - 99%) and finally red (100% and above) increasing incrementally with the percentage utilization.

Fly:Luffing

Fly: This is whether or not a fly jib is erected. It will either show Fly with the fly description or No Fly depending on selection.

MAIN BOOM

Program: This is the current program selected. Any error messages will be displayed in this block (see Figure 10 – i.e. Anti-2-Block). If there is more than one error, it will scroll across the block.

ERROR MESSAGES - FIGURE 10 AND TABLE 1

The TS7000 will sound a buzzer and the green block will be replaced by an orange or red block at the top of the screen if any error occurs on the system. These errors are displayed at the bottom of the screen e.g. Anti-2-Block where program selection is normally displayed, if more than one error occurs the errors will scroll on the bottom until rectified.

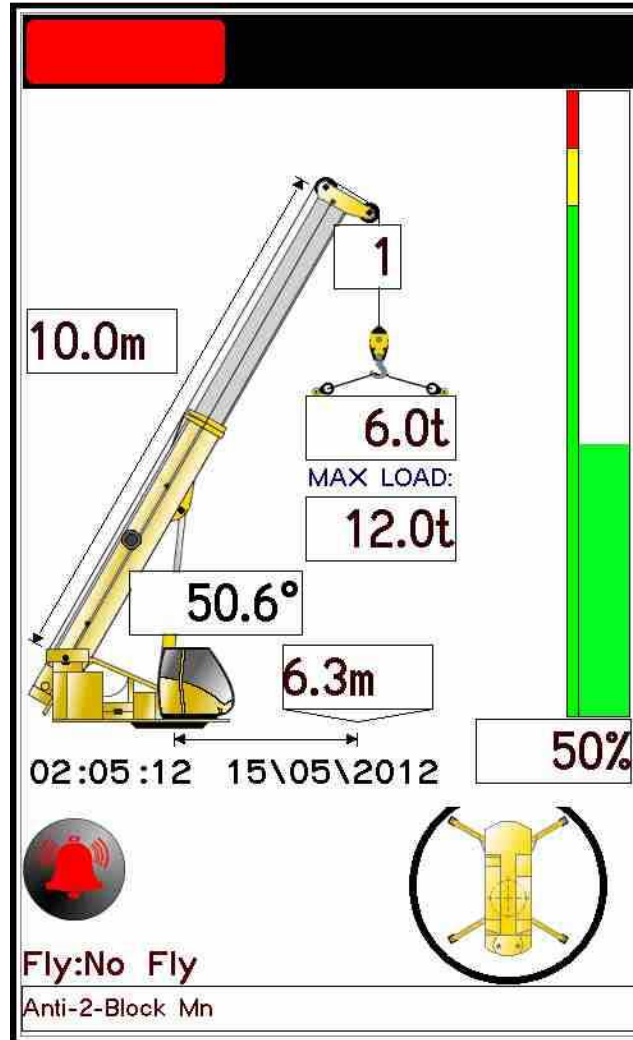

Figure 10

For all the errors we have given indication of the problem and the common solutions, these can be done by the operator or an individual who has some basic crane knowledge. If the given solution does not work please contact the original installer or someone from our service network where we can try and help telephonically or send a technician to repair the system.

SAFE-AID TS7000 SYSTEM ERROR TABLE – TABLE #1

SCREEN DISPLAY	INDICATION	OPERATOR SOLUTION
Slew Error	Boom is not over an area covered by the current duty selected.	Slew the boom into a safe working area.
High Angle	The angle of the boom is above the crane manufacturer's maximum specification.	Lower boom.
Low Angle	The angle of the boom is below the crane manufacturer's minimum specification.	Raise boom.
Length Exceeded	The length allowed for your selected configuration has been exceeded or the length is above the maximum manufacturer's specified length.	Retract boom or check program selection correct.
Extend Boom	You are working below the specified working length for the selected boom configuration.	Extend boom to the correct working length & check program selection.
M400 No Coms	No communication between mother board and display.	Call installer or service technician.
Anti-2-Block	The main or auxiliary hook has been pulled up too close to the boom head sheave wheels.	Lower Main or Auxiliary Winch.
Anti-2-Block Fly	The hook has been pulled up too close to the fly jib tip sheave wheel.	Lower Auxiliary winch.
Main A400 No Coms	No communication between main angle board and motherboard/display.	Call installer or service technician.
Aux A400 No Coms	No communication between auxiliary angle board and motherboard/display.	Call installer or service technician.
Overload	The maximum rated capacity has been reached - you are in overload.	Move load into safe working position - winch down, boom up or retract boom.
Telesequence Error	The boom has been telescoped incorrectly NOT according to the manufacturer's specifications.	Retract boom fully and telescope according to the manufacturer's specifications.
R400 No Coms	No communication between relay board and motherboard/display.	Call installer or service technician.
No Load Chart Data	You are working out of the manufacturer's specified working range – incorrect working radius	Lower Boom to within the manufacturer's specified working range.
No Moment Value	Pressure Error	No empty and loaded moment data at specific length and angle.
Tilt Error X Axis	Crane has tilted over maximum allowed tilt on the X axis (Left & right of carrier)	Level crane to within specified tilt range.

SCREEN DISPLAY	INDICATION	OPERATOR SOLUTION
Tilt Error Y Axis	Crane has tilted over maximum allowed tilt on the Y axis (Front & rear of carrier)	Level crane to within specified tilt range.
Anti-2-Block Short Circuit	There is a short circuit between the two A-2-B wires.	Call installer or service technician.
Anti-2-Block Fly Short Circuit	There is a short circuit between the two A-2-B wires on the fly jib.	Call installer or service technician.
A400 Tilt No Coms	No communication between A400 Tilt board and motherboard/display.	Call installer or service technician.
O/R Front Left Error	Front Left Outrigger is not extended to the correct length.	Extend Front Left Outrigger to correspond to program selection.
O/R Front Right Error	Front Right Outrigger is not extended to the correct length.	Extend Front Right Outrigger to correspond to program selection.
O/R Rear Left Error	Rear Left Outrigger is not extended to the correct length.	Extend Rear Left Outrigger to correspond to program selection.
A400 Twin Length No Coms	No communication between A400 Twin Length board and Main A400/motherboard/display.	Call installer or service technician.
O/R Rear Right Error	Rear Right Outrigger is not extended to the correct length.	Extend Rear Right Outrigger to correspond to program selection.
Main Dump Short Circuit	Short circuit on the Main Dump Output.	Call installer or service technician.
Main Dump Open Circuit	Open circuit on the Main Dump Output.	Call installer or service technician.
Output #2 Short Circuit	Short circuit on Output 2.	Call installer or service technician.
Output #2 Open Circuit	Open circuit on the Output 2.	Call installer or service technician.
No Dump Supply	No supply (power or ground) on the selected dump supply.	Check 5A dump fuse.
A400 Windspeed No Coms	No communication between A400 Windspeed board and Main A400/motherboard/display.	Call installer or service technician.
Rope Overload	The maximum line pull specified by the manufacturer has been exceeded.	Put Load down – check correct reeving selected.
Maximum Windspeed	Maximum wind speed limit specified by the manufacturer has been reached.	Check manufacturers limit has been set correctly.
Output #3 Short Circuit	Short circuit on Output 3.	Call installer or service technician.
Output #3 Open Circuit	Open circuit on the Output 3.	Call installer or service technician.
Output #4 Short Circuit	Short circuit on Output 4.	Call installer or service technician.
Output #4 Open Circuit	Open circuit on the Output 4.	Call installer or service technician.

SCREEN DISPLAY	INDICATION	OPERATOR SOLUTION
Output #4 Error	Error on Output 4.	Call installer or service technician.
Output #5 Error	Error on Output 5.	Call installer or service technician.
Output #6 Error	Error on Output 6.	Call installer or service technician.
Keyswitch Override	Override Key has been turned to the override position - key cannot be removed from the switch	Turn override key to position where key can be removed.
Raise Fly Jib	Hydraulic off settable fly angle needs to be closer to the selected offset - more towards the minimum offset.	Raise the fly jib towards minimum offset (0° is straight in line with main boom) - check program selection.
Lower Fly Jib	Hydraulic off settable fly angle needs to be closer to the selected offset - more towards the maximum offset.	Lower the fly jib towards maximum offset (45° is 45° below the straight line of the main boom) - check program selection.
2nd Main A400 No Coms	No communication between 2nd Main Angle board and Main A400/motherboard/display.	Call installer or service technician.
Length Error	Length potentiometer is reading below minimum allowed reading - 750-770 Counts.	Call installer or service technician.
P/Tdx Bottom Error	Bottom pressure transducer reading below 3.75mA – 5400 - 5410 counts.	Call installer or service technician.
P/Tdx Top Error	Top pressure transducer reading below 3.75mA – 5400 - 5410 counts.	Call installer or service technician.
Extend Fly jib	Hydraulically extendable fly length is shorter than the selected program.	Extend fly jib to the correct working length – check program selection.
Retract Fly Jib	Hydraulically extendable fly length is longer than the selected program.	Retract fly jib to the correct working length – check program selection.
User Minimum Length Error	Main boom length is less than the user selected minimum length setting.	Extend main boom or clear user selected minimum length.
User Maximum Length Error	Main boom length is greater than the user selected maximum length setting.	Retract main boom or clear user selected maximum length.
User Minimum Radius Error	Radius is less than the user selected minimum radius setting	Extend or lower main boom to increase working radius or clear user selected minimum radius.
User Maximum Radius Error	Radius is greater than the user selected minimum radius setting.	Retract or raise main boom to decrease working radius or clear user selected maximum radius.
User Minimum Angle Error	Boom angle is less than the user selected minimum angle setting.	Raise main boom or clear user selected minimum angle.
User Maximum Angle Error	Boom angle is greater than the user selected maximum angle setting.	Lower main boom or clear user selected maximum angle.

WORKING OPERATIONS

As an operator, there are **FIVE** different areas/places on the operating screen which can be pressed to initiate a function.

1. **The top left hand corner.** This is to get into calibration mode – this enters into the PROGRAMMING screen that will ask for a password (see calibration manual). To return to the working screen press Enter.
2. **The Tare** which is activated by pressing directly on the lifted load when a load is displaying on the hook. The Lifted Load will be zeroed allowing for a reading excluding the original weight. The original weight is still taken into account when calculating the percentage of utilization therefore the TS7000 will still give the correct 90% and 100% warnings. Once pressed the numbers under the lifted load will flash showing no value, only 0,0t and the GREEN BLOCK will flash intermittently. Thereafter, if a weight is lifted, only the weight lifted will be displayed and not the weight together with hook block or any other additional weight. To return to the actual load, press the lifted load again, it will stop flashing showing the actual load on the hook.

3. **The buzzer override** which is located in the **bottom left** of the screen  5 seconds after an error condition occurs. When the buzzer override is pressed the AMBER BLOCK

will flash intermittently a red cross will be placed through the buzzer picture  and the buzzer will shut off. The buzzer override is needed for each alarm condition this means if you have overridden one error and another occurs the buzzer will sound again.

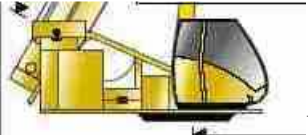
4. **The program selection** is the crane graphic on the screen.  If at any given time the current program needs to be changed, press on the crane graphic and this will return to the first selection as if powering up for the first time. For example, if the crane is working Main Boom on Outriggers and now needs to work on tyres, immediately change the program to Main Boom on Rubber as the cranes rated capacities and limits will be different.

Note: In certain circumstances Program Lockout has been enabled which allows one Main Program and one Auxiliary Program with a fixed reeving for each. This is a rigging selection so consult the riggers manual for more information.

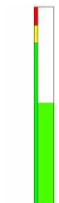
5.  **The momentary override** which is the utilisation bar graph on the screen. By holding your finger anywhere in this area the dump solenoids (lever cut-off) can be overridden momentarily (while pushing on the screen in that area) to allow the crane to be folded up.

Note: This function can only be used if activated by the installer.

INDICATING STATUS LIGHTS AND DUMP OUTPUT (LEVER CUT-OFF) - TABLE # 2

There are **three BLOCKS** that are illuminated like a traffic robot situated on the top of the display screen.



These **BLOCKS** are illuminated depending on the working state and error conditions. These **BLOCKS** are a basic way of checking the LMI.

The following chart gives you the **BLOCK** status, buzzer status as well as the status of the **DUMP** (Lever Cut-off). **DUMP** the crane will cut-out and **NO DUMP** you are able to work. To rectify or check the error, please check the error message chart (Table 1) on page 14 & 15.

When the system is in the correct working condition (no errors), the GREEN BLOCK will be permanently on.

SYSTEM MESSAGE	BLOCK STATUS	DUMP STATUS	BUZZER STATUS
No Selection	ALL FLASHING	ON	INTERMITTENT
Slew Error	RED	ON	ON
High Angle	RED	ON	ON
Low Angle	RED	ON	ON
Length Exceeded	RED	ON	ON
Extend Boom	ORANGE	OFF	MEDIUM
M400 NC	RED	ON	ON
Anti-2-Block	RED	ON	ON
Anti-2-Block Fly	RED	ON	ON
Main A400 NC	RED	ON	ON
Aux A400 NC	RED	ON	ON
Overload	RED	ON	ON
≥90% Loading	ORANGE	OFF	MEDIUM
Telesquence Error	RED	ON	ON
R400 NC	RED	ON	ON
No Load Chart Data	RED	ON	ON
No Moment Value	RED	ON	ON
Tilt Error X Axis	RED	ON	ON
Tilt Error Y Axis	RED	ON	ON
Anti-2-Block Short	RED	ON	ON
Anti-2-Block Fly Short	RED	ON	ON
A400 Tilt NC	RED	ON	ON
O/R Front Left Err	RED	ON	ON
O/R Front Right Err	RED	ON	ON
O/R Rear Left Err	RED	ON	ON
O/R Rear Right Err	RED	ON	ON
Main Dump Short	RED	ON	ON
Main Dump Open	RED	ON	ON

SYSTEM MESSAGE	BLOCK STATUS	DUMP STATUS	BUZZER STATUS
Output 2 Short	RED	ON	ON
Output 2 Open	RED	ON	ON
No Dump Supply	RED	ON	ON
Keyswitch Override	RED	ON	ON
A400 Windspeed NC	RED	ON	ON
Rope Overload	RED	ON	ON
Maximum Windspeed	RED	OFF	ON
Output 3 Short	RED	ON	ON
Output 3 Open	RED	ON	ON
Output 4 Short	RED	ON	ON
Output 4 Open	RED	ON	ON
Output 4 Error	RED	ON	ON
Output 5 Error	RED	ON	ON
Output 6 Error	RED	ON	ON
Keyswitch Override	RED	ON	ON
Raise Fly	RED	ON	ON
Lower Fly	RED	ON	ON
2nd Main A400 NC	RED	ON	ON
Length Error	RED	ON	ON
P/Tdx Bottom Error	RED	ON	ON
P/Tdx Top Error	RED	ON	ON
Extend Fly	RED	ON	ON
Retract Fly	RED	ON	ON

NOTES:

- The **amber BLOCK** will flash when buzzer override is activated, and if a new error occurs the buzzer will be reactivated and will have to be overridden again.
- The **green BLOCK** will flash when TARE function is used and the crane is within the limits specified by the manufacturer, if not normal errors will resume.

TOUCH SCREEN CALIBRATION – FIGURES 11, 12 & 13

If the touch screen is not responding correctly to touch the touch screen may need to be calibrated.

Switch the TS7000 system power off then power up the TS7000 and wait for the splash screen (Figure 11) to appear.

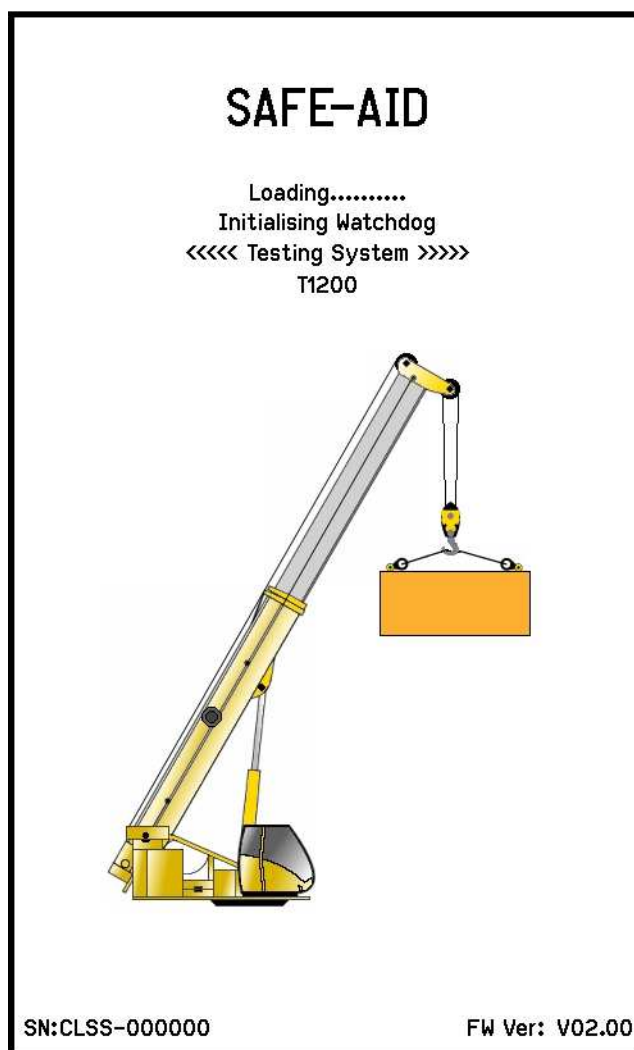

Figure 11

While the splash screen is on, press and hold the screen for five full seconds in the centre until the touch calibration is activated and loaded (Figure 12).

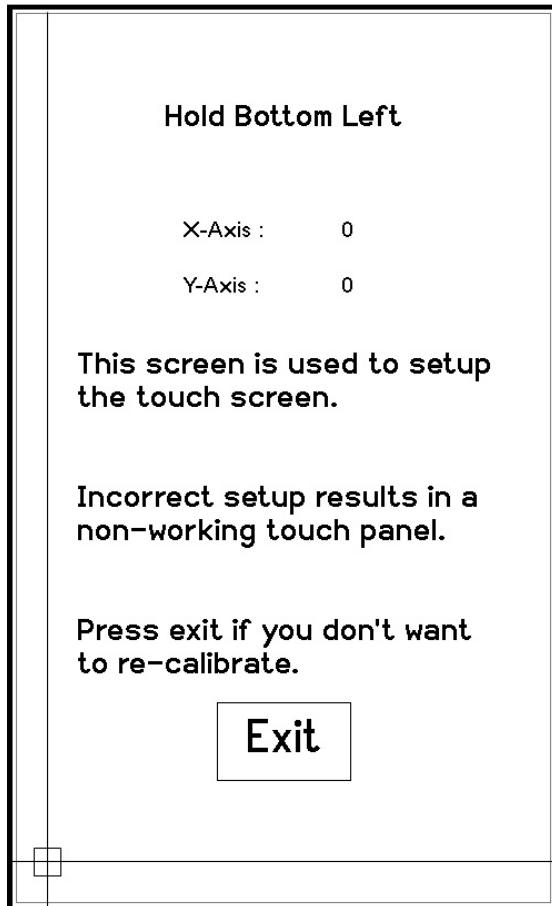

FIGURE 12

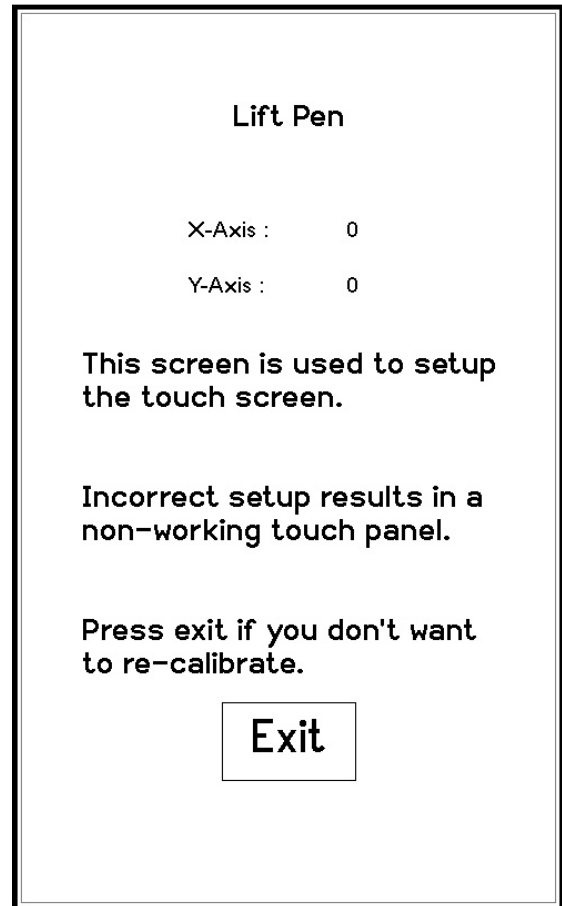

FIGURE 13

If the calibration screen has been entered by accident and touch calibration is not necessary, press the **Exit** button without pushing anywhere else on the screen. This takes you out of the touch screen calibration and back to the normal operations.

If touch calibration is required follow the below procedures:

Press and hold finger where the two lines meet inside the small box (Figure 12 bottom left hand corner). Calibration works fine when using a finger but for better results use a pen taking care not to press too hard or you will damage the screen.

Hold finger/pen in this area until prompted to lift (Figure 13). The software will then ask for three more touch zones resulting in co-ordinates for all four corners of the screen.

Once calibration is complete the software automatically goes to the first selection screen.

QUICK USE FLOW CHART

